

PLAN VIEW

Technical Data:

type: GLYCOL CHILLER
 output: 1.5kw
 ventilation: WATER COOLED WITH HEAT DUMP
 finish: BLACK PLASTISOL COATED MILD STEEL
 circulation: SINGLE OR TWIN PUMP
 nett weight: 85 KILOGRAMS
 refrigerant: R134A
 voltage: 230v/1ph/50hz
 max.operating current: 4AMPS
 tank capacity: 60 LITRES
 max.ambient temp: 32°C
 minimum glycol concentration 30%

M60000 TEN LITRE GLYCOL PACK COMPRISING:

10 litres monoproplene food grade glycol
 10 litre plastic container
 packed in reinforced safety carton
 5 litre containers available on request

OPTIONS:

IMMERSION 10-PRODUCT COILS

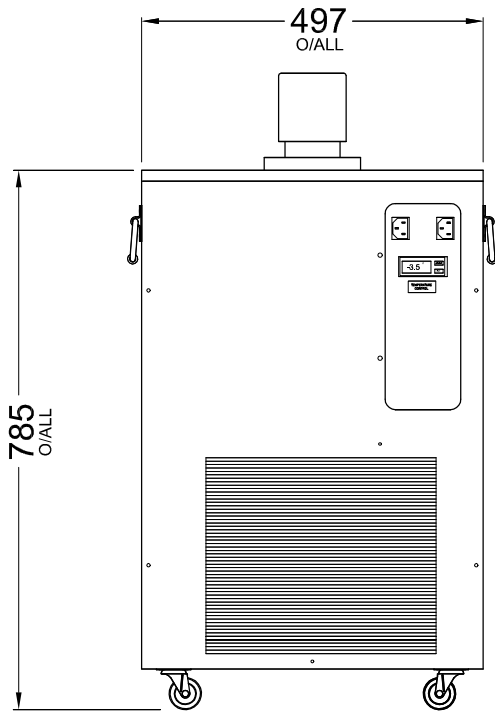

FRONT VIEW

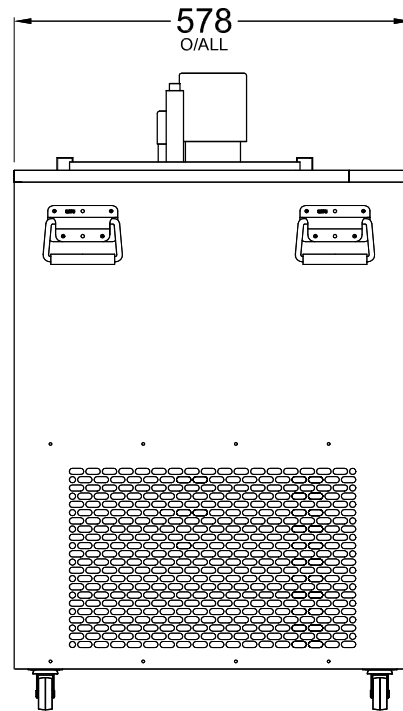

SIDE VIEW

CUSTOMER:

**WATER COOLED VERSION.
 (SHOWN AS SINGLE PUMP)**

SEE SEPARATE DRAWING FOR HEAT DUMP DETAILS



UNIVERSAL DISPENSE SYSTEMS
 UNIVERSAL BUILDINGS GREEN LANE
 HOUNSLOW MIDDLESEX TW4 6DF
 TEL: 0208 570 4455 FAX: 0208 572 2389

PRODUCT DESCRIPTION

1.5 KW chiller (water cooled)

PRODUCT CODE

ZERO K150